

STANCHION RAILS (FOR QUEUE LINES) ARE EITHER CORE-DRILLED (POSTS SET INTO FLOOR WITH EPOXY/CEMENT) OR SURFACE-MOUNTED (BOLTED THROUGH FLANGES ATTACHED TO POSTS)

OVERALL CONSTRUCTION (SEE PAGE 2 FOR INSTALLATION)

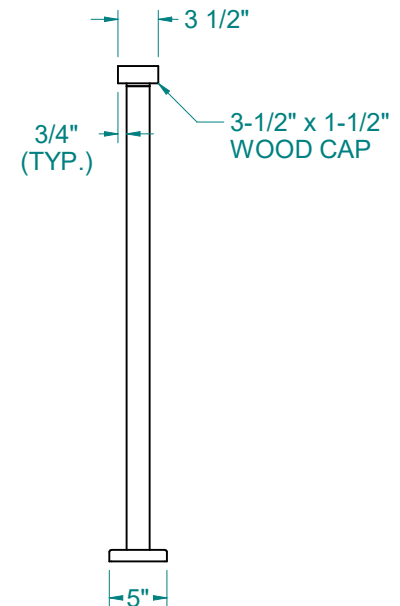

INSTALLATION PLAN

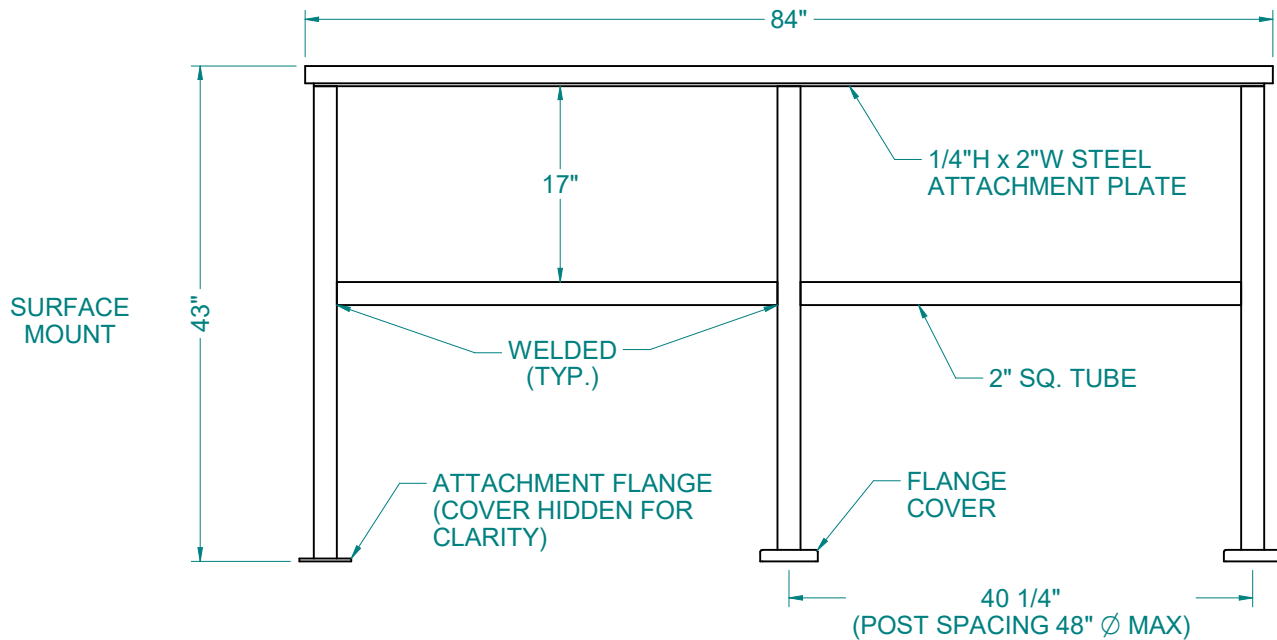
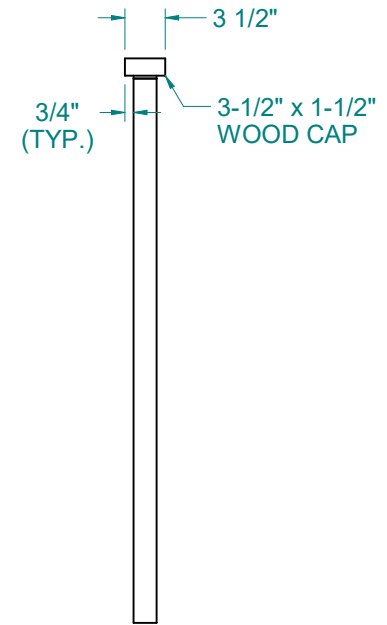
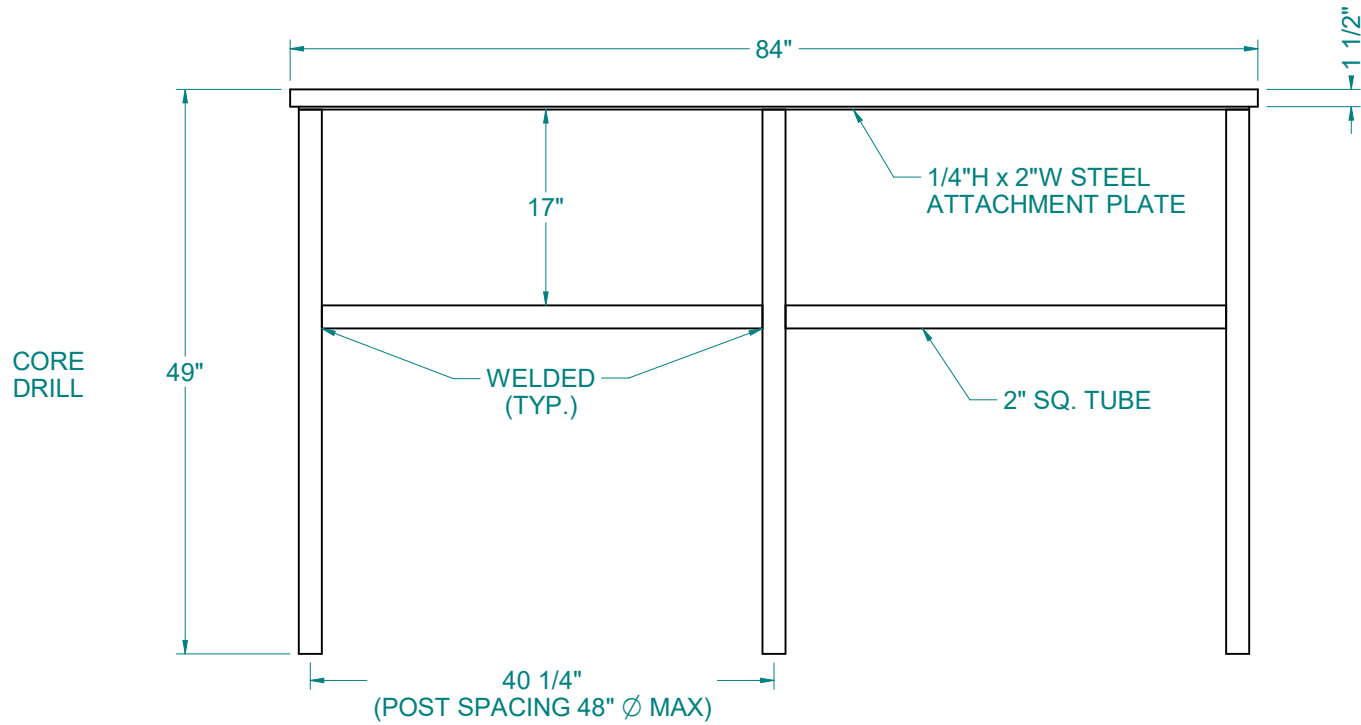