

42" Tall T-BASE TABLE ASSEMBLY INSTRUCTIONS

88-0231 & 88-0141 - Table 24" x 42" x 42"H

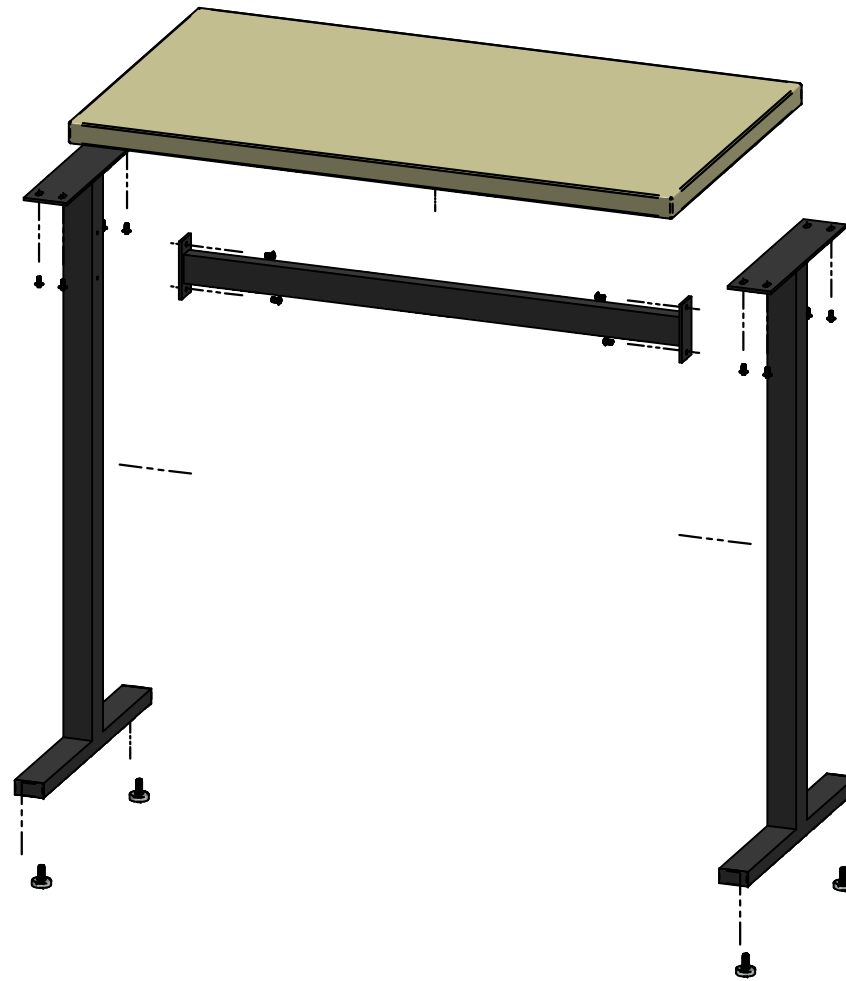

HIGH TOP T-BASE TABLE ASSEMBLY INSTRUCTIONS

MATERIALS

Table Package Includes

- Table Top
- 2 T-Bases and Crossbar
- 5/16"-18 Screws to attach T-Bases to Top
- 1/4"-20 Screws to attach Crossbar to T-Bases
- Allen Key
- Levelers

INSTRUCTIONS:

1. Open box containing top, make sure threaded insert are facing up
2. Loosely attach t-bases to top using 5/16"-18 screws
3. Loosely attach crossbar to t-bases using 1/4"-20 screws
4. Tighten down all screws with allen key

NOTE: Tightening the crossbar screws or the top screws before the others have been started may result in misalignment of one set of holes

5. Screw levelers into base

NOTE: Do not over-tighten the screws that attach the top and base. Solid wood expands and contracts in width seasonally. Over-tightening may cause tops to split.

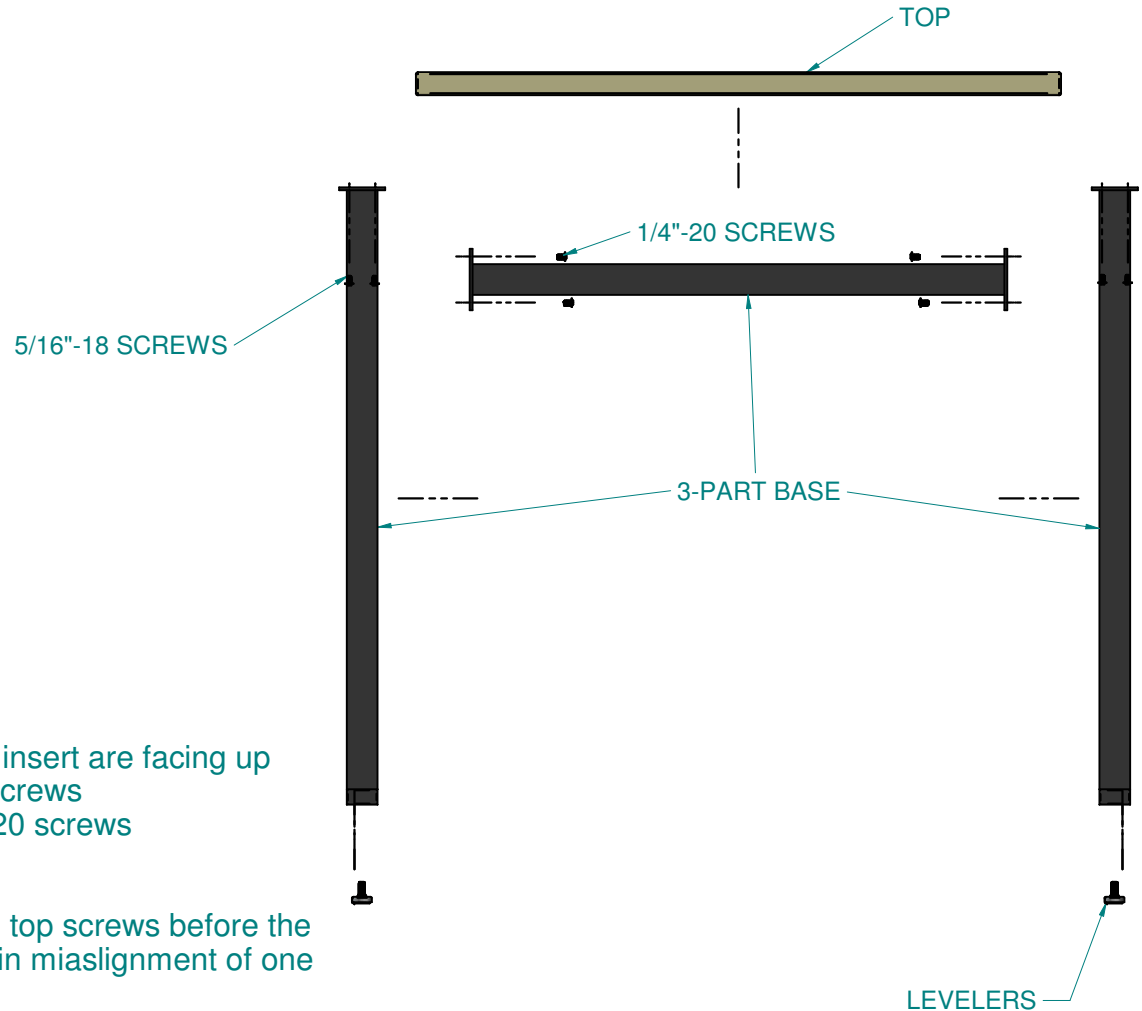

TOP AND BASE ALIGNMENT

When attaching top to base, keep the slotted holes on the table base flange perpendicular to the grain direction of the table top. See Detail A

NOTE: Do not over-tighten the screws that attach the top and base. Solid wood expands and contracts in width seasonally. Over-tightening may cause tops to split.

