

BOOTH INSTALLATION INSTRUCTIONS:

88-0120 Booth 1PS 24W Unfinished Back
88-0123 Booth 2PS 48W Unfinished Back
88-0126 Booth 3PS 72W Unfinished Back

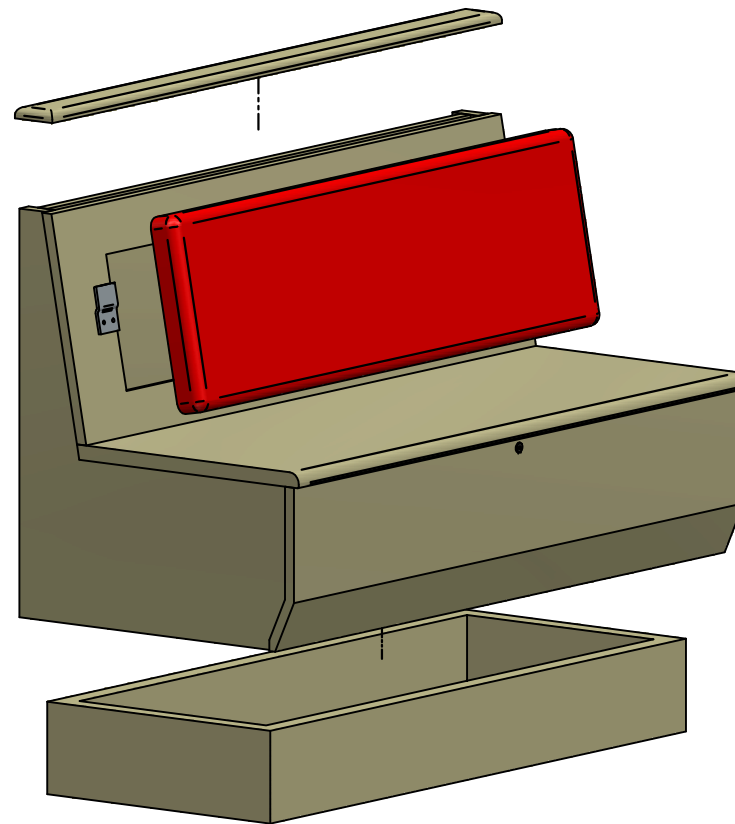

FIVE GUYS PROGRAM

MOSER CONTRACT
72 Wrights Landing // Auburn ME // 04210
www.fg.mosercontract.com

Five Guys

Booth Installation Instructions

NOTES PRELIMINARY DOCUMENT - NOT FOR DISTRIBUTION TO INSTALLERS

PAGE 1 OF 5

REVISION

BY PeterB

ITEM 88-0120, 88-0123, 88-0126

DWG Booth Unfinished Back Installation instructions.dft

DATE 02/11/16

MATERIALS

Materials Required for Installation (to be provided by Five Guys installation contractor):

- Shims
- 2x4 Blocking
- Tile drill bit
- Screws to attach plinth to floor
- Screws to attach booth plinth
- Trim head screws to attach Top Cap
- Oil Based Filler Putty
- Polyurethane Construction Adhesive

Booth Package Includes:

- Booth Body
- Back Cushion
- Top Cap
- Plinth Base

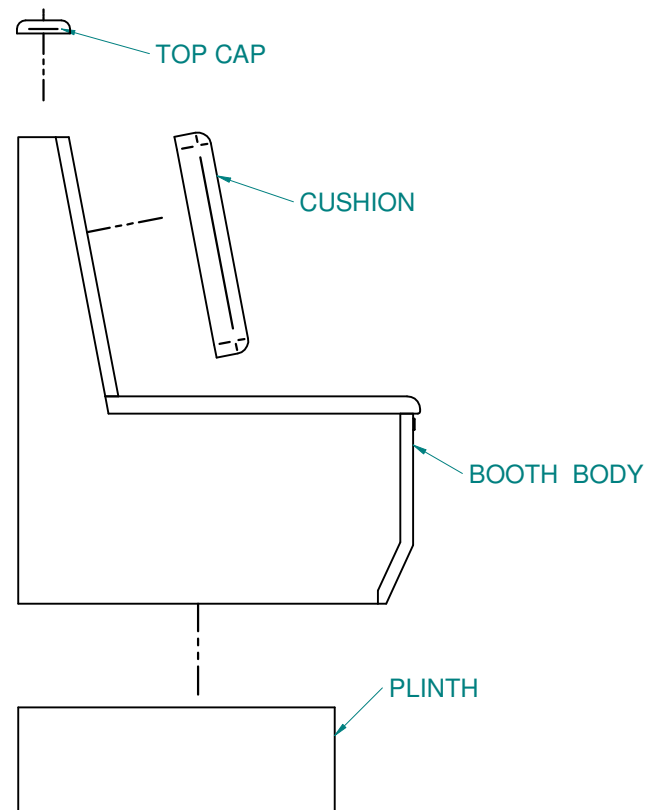

FIVE GUYS PROGRAM

MOSER CONTRACT
72 Wrights Landing// Auburn ME // 04210
www.fg.mosercontract.com

Five Guys

Booth Installation Instructions

NOTES PRELIMINARY DOCUMENT -NOT FOR DISTRIBUTION TO INSTALLERS

PAGE 2 OF 5

REVISION

BY PeterB

ITEM 88-0120, 88-0123, 88-0126

DWG Booth Unfinished Back Installation instructions.dft

DATE 02/11/16

STEP ONE:

- Remove Plinth from booth body if it is attached
- Place Plinth on floor in desired location
- Shim Plinth Level
- Attach 2x4 blocking to floor inside Plinth with screws and adhesive
- Screw Plinth to blocking through outside of Plinth
- Screw Plinth to Walls

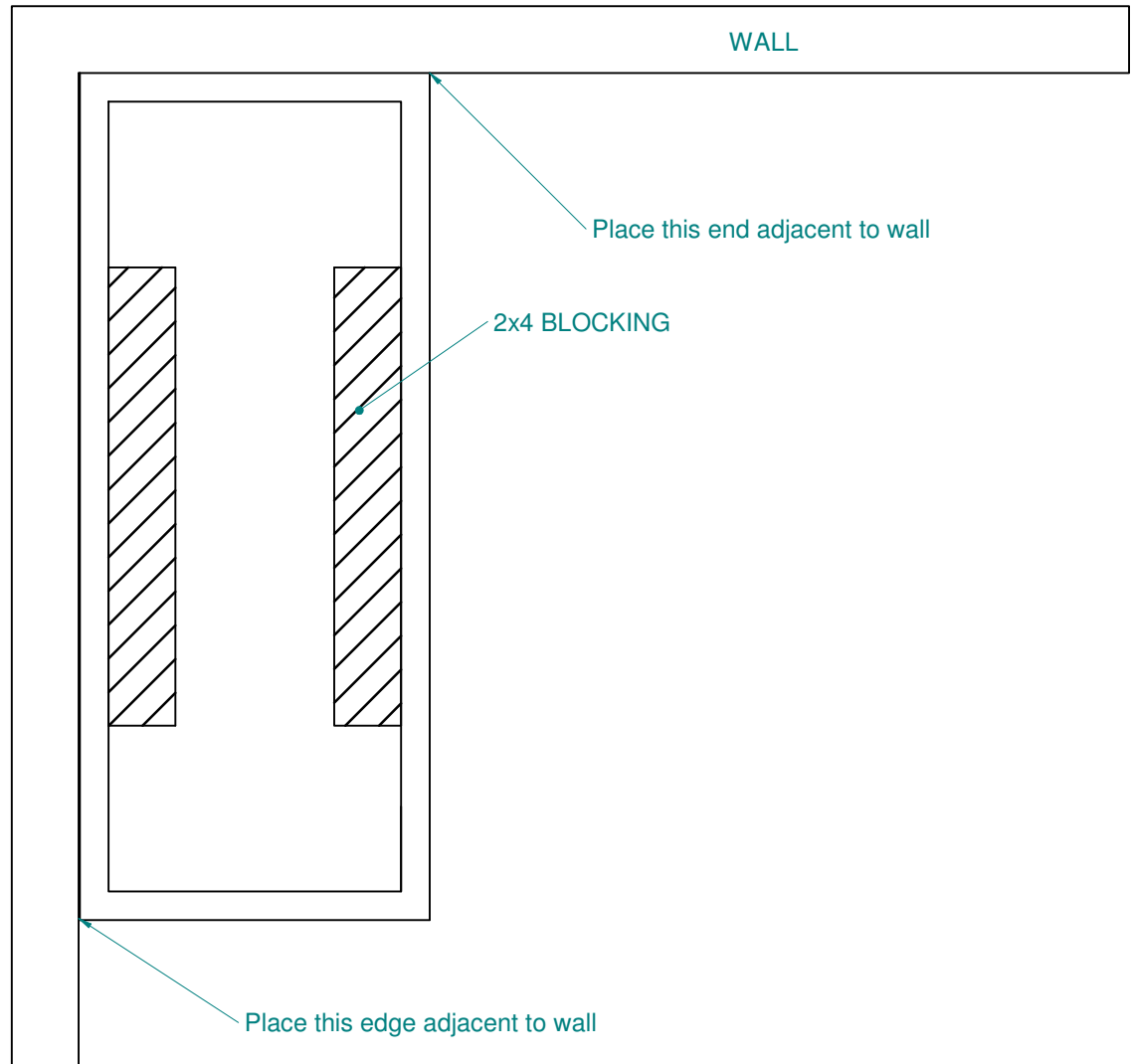

FIVE GUYS PROGRAM

MOSER CONTRACT
72 Wrights Landing // Auburn ME // 04210
www.fg.mosercontract.com

Five Guys

Booth Installation Instructions

NOTES PRELIMINARY DOCUMENT -NOT FOR DISTRIBUTION TO INSTALLERS

PAGE 3 OF 5

REVISION

BY PeterB

ITEM 88-0120, 88-0123, 88-0126

DWG Booth Unfinished Back Installation instructions.dft

DATE 02/11/16

STEP TWO:

- Remove Back Cushion if it is attached (see page 5)
- Remove Allen Screw from front of Booth
- Remove Seat Panel from Booth (Panels are not interchangeable amongst booths)
- Place Booth on Plinth against wall
- Scribe Booth to wall if necessary
- Anchor Booth Body to Plinth and Wall
 - Screw through booth bottom to plinth corner blocks
 - Screw through booth back and side into walls

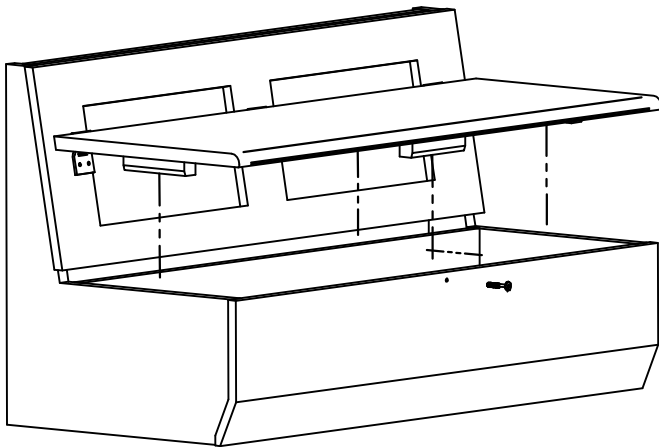

REMOVE SCREW AND SEAT

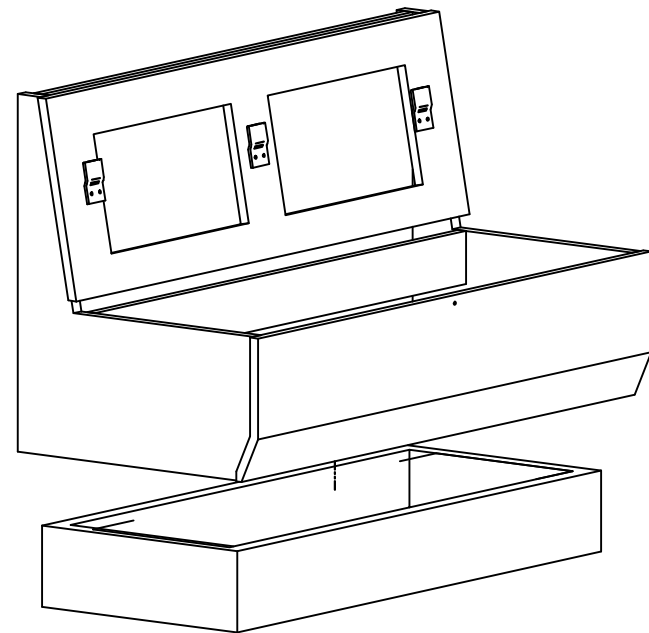

PLACE ON PLINTH AND ATTACH

FIVE GUYS PROGRAM

MOSER CONTRACT
72 Wrights Landing // Auburn ME // 04210
www.fg.mosercontract.com

Five Guys

Booth Installation Instructions

NOTES PRELIMINARY DOCUMENT - NOT FOR DISTRIBUTION TO INSTALLERS

PAGE 4 OF 5

REVISION

BY PeterB

ITEM 88-0120, 88-0123, 88-0126

DWG Booth Unfinished Back Installation instructions.dft

DATE 02/11/16

STEP THREE:

- Re-install Seat Panel and Screw
- Using trim screws, screw Top Cap in place.
- Fill nail holes with Putty
- Install Back Cushion by sliding down on to clips and then screwing tabs at bottom of cushion into back panel

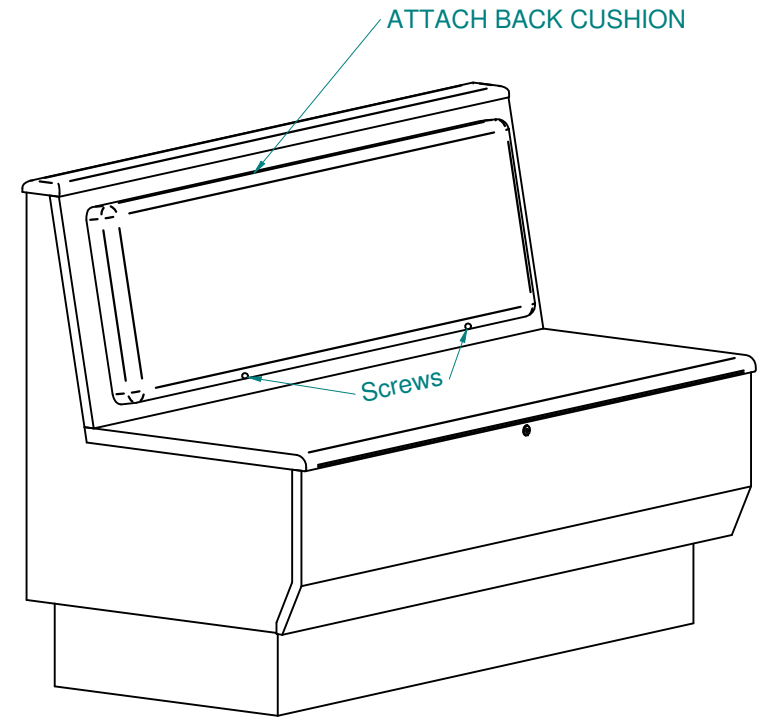
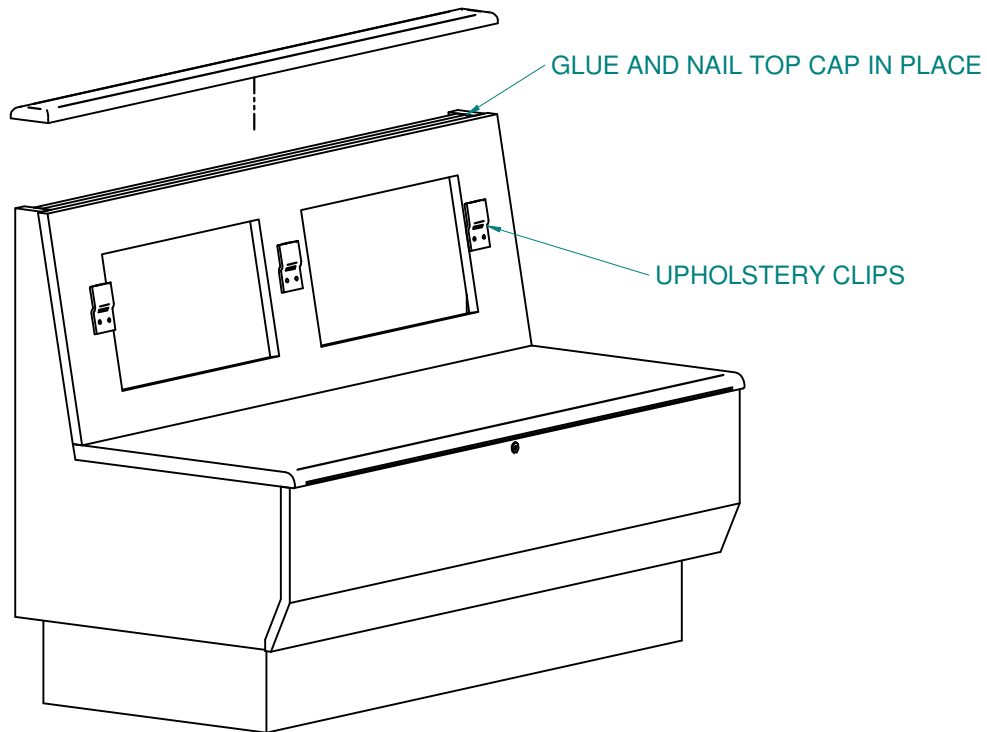

FIVE GUYS PROGRAM

MOSER CONTRACT
72 Wrights Landing // Auburn ME // 04210
www.fg.mosercontract.com

Five Guys

Booth Installation Instructions

NOTES PRELIMINARY DOCUMENT - NOT FOR DISTRIBUTION TO INSTALLERS

PAGE 5 OF 5

REVISION

BY PeterB

ITEM 88-0120, 88-0123, 88-0126

DWG Booth Unfinished Back Installation instructions.dft

DATE 02/11/16