

BOOTH INSTALLATION INSTRUCTIONS:

88-0121 Booth 1PS 24W Finished Back
88-0124 Booth 2PS 48W Finished Back
88-0127 Booth 3PS 72W Finished Back

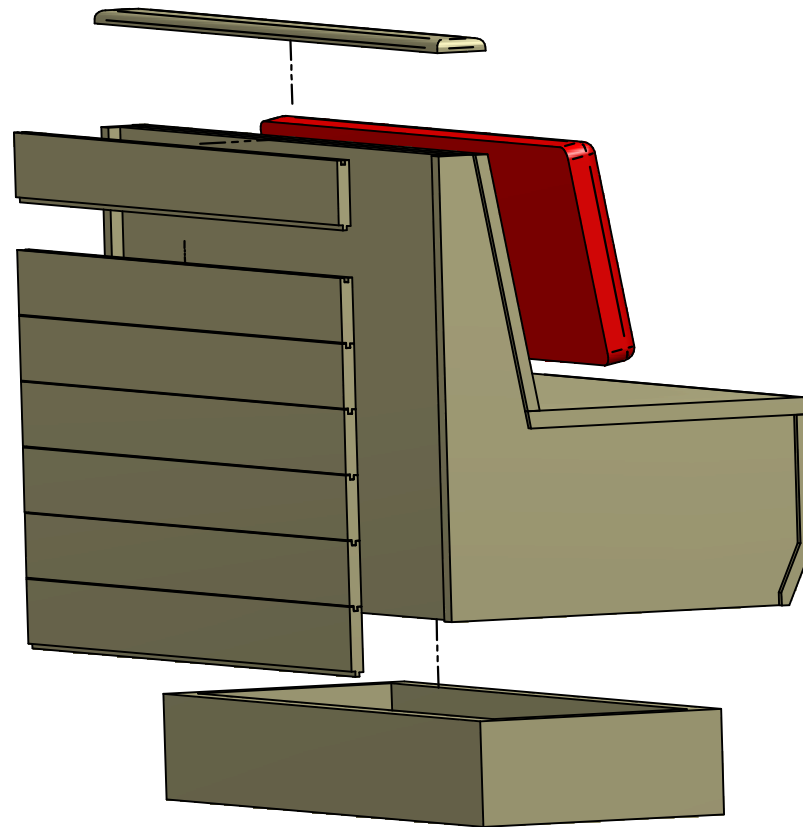

MATERIALS

Materials Required for Installation (to be provided by Five Guys installation contractor):

- Shims
- Tile drill bit
- 2x4 Blocking
- Screws to attach plinth to floor
- Screws to attach booth plinth
- Trim head screws to attach Top Cap
- Oil Based Filler Putty
- Polyurethane Construction Adhesive

Booth Package Includes:

- Booth Body
- Back Cushion
- Top Cap (Shipped detached)
- Plinth Base
- Wall Paneling (Shipped detached)

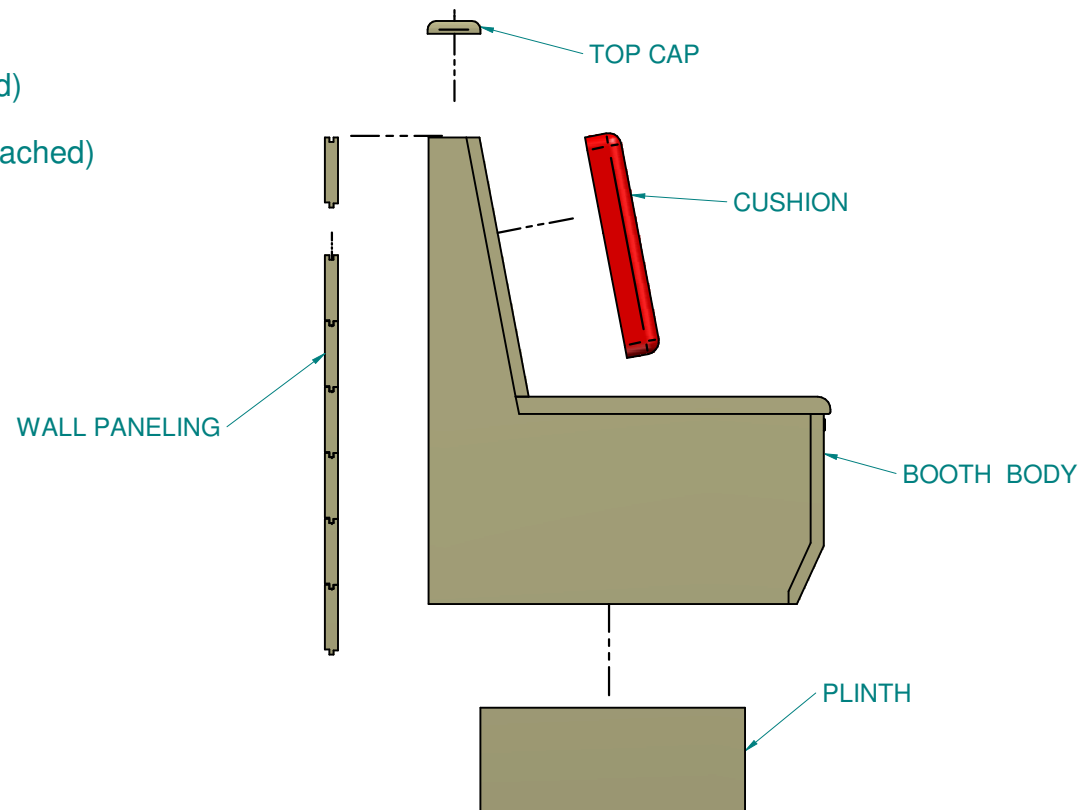

STEP ONE:

- Remove Plinth from booth body
- Place Plinth on floor in desired location
- Shim Plinth Level
- Attach 2x4 blocking to floor inside Plinth with screws and adhesive
- Screw Plinth to blocking through outside of Plinth
- Screw Plinth to Walls

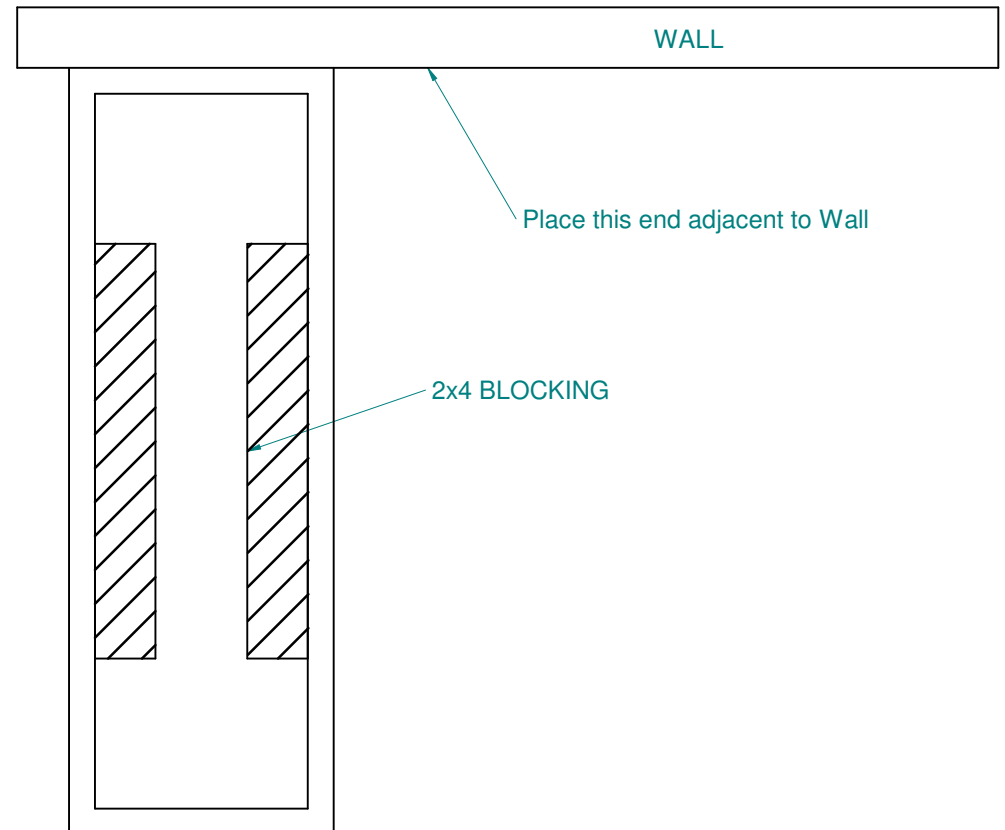

STEP TWO:

- Remove Back Cushion if it is attached (see page 5)
- Remove Allen Screw from front of Booth
- Remove Seat Panel from Booth (Panels are not interchangeable amongst booths)
- Place Booth on Plinth against wall
- Scribe Booth to wall if necessary
- Anchor Booth Body to Plinth and Wall
 - Screw through booth bottom to plinth corner blocks
 - Screw through booth side into wall

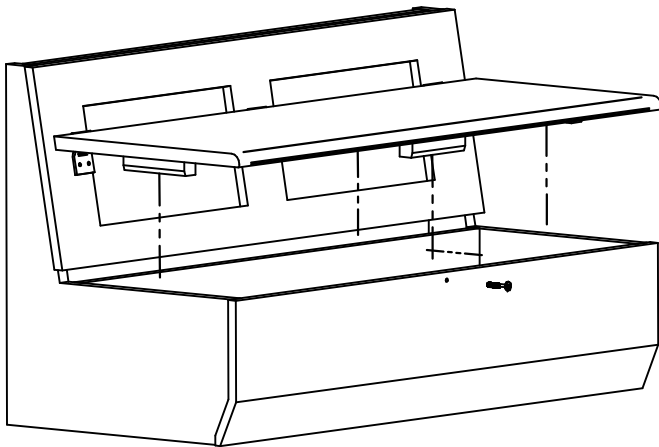

REMOVE SCREW AND SEAT

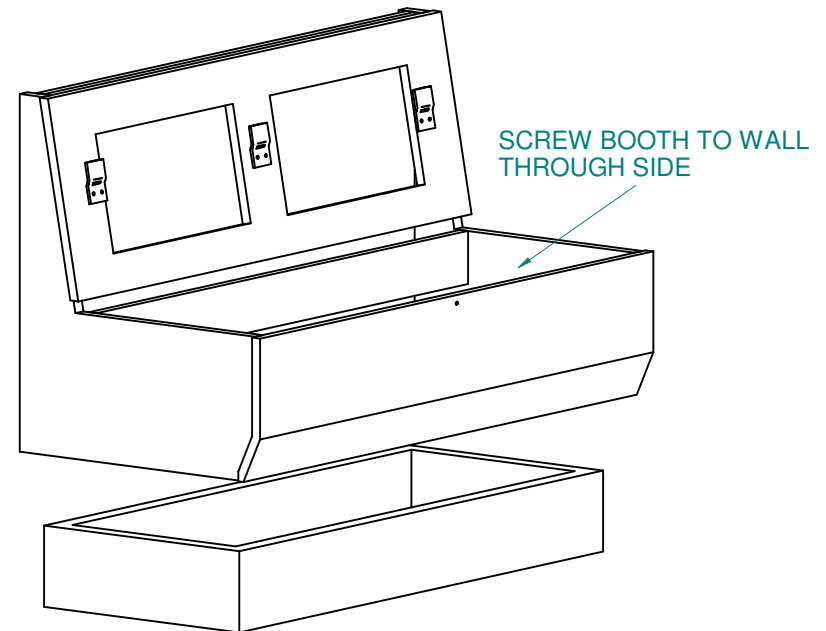

PLACE ON PLINTH AND ATTACH

STEP THREE:

- Re-install Seat Panel and screw
- Using trim screws, screw Top Cap in place
- Fill nail holes with Putty
- Install Back Cushion by sliding down on to clips and then screwing tabs at bottom of cushion into back panel
- Cut wall paneling to fit inside booth back. Nail through paneling tongue to booth back panel

